

HIGH PRODUCTIVITY SWIFT VERTICAL MACHINING CENTER

# **SVM 4100 · 5100L**

**SVM 4100**  
**SVM 5100L**

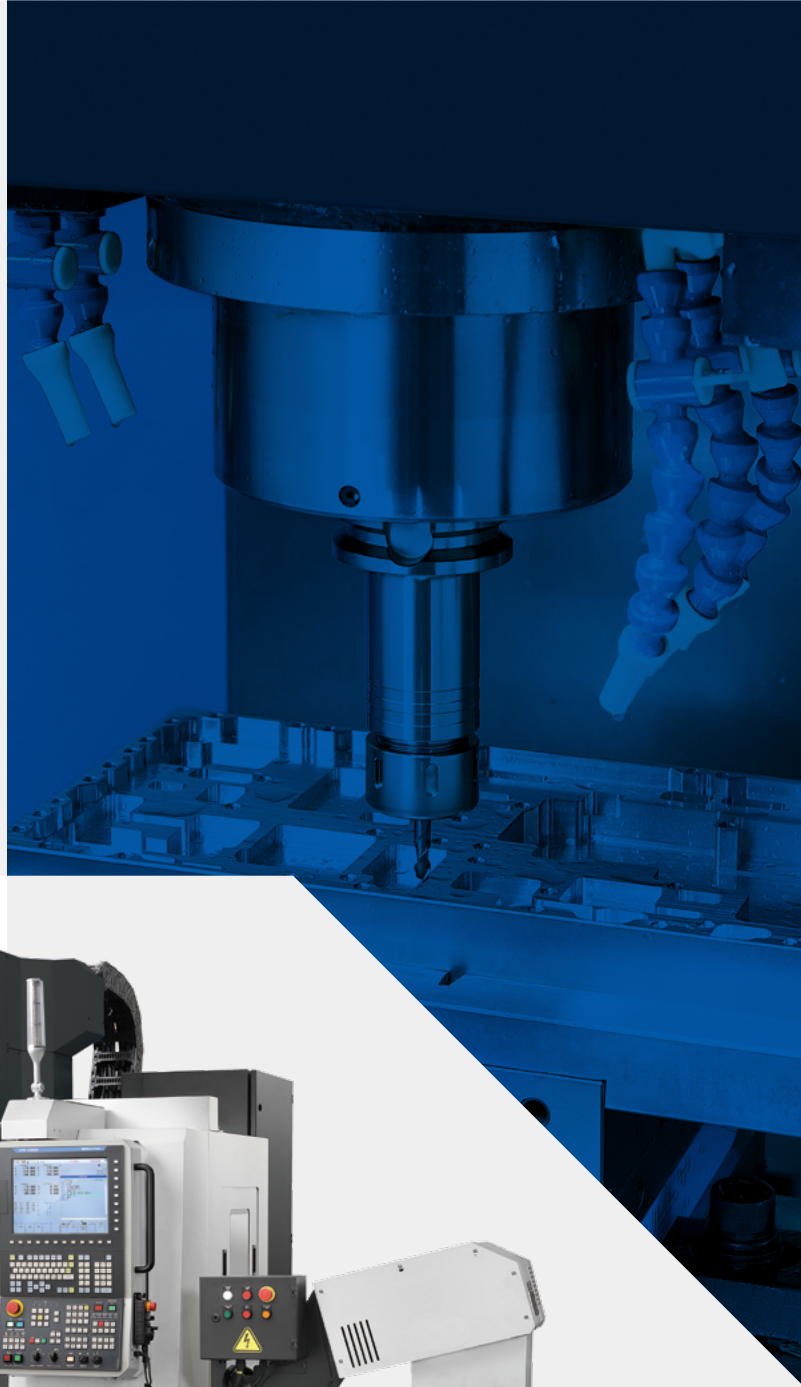

# SVM 4100 · 5100L

The SVM series vertical machining center has been developed to meet the increased demand for the machining of aluminum die castings in the Automotive and IT industries. In addition, it can be used for general-purpose light-duty machining of steel parts. The machine's performance has been optimized to provide shorter cycle times by improving the acceleration/deceleration times of the X/Y/Z axes and spindle, thereby reducing the non-cutting times. In order to design a machine that can handle a wide range of parts, DN Solutions has created a machine with the largest machining envelope in its class, together with many other important features such as thermal displacement correction for the direct-drive spindle and the EZ work.

SVM series is a lightweight cutting optimization product that boasts excellent production performance and provides final production efficiency to customers who process lightweight materials such as aluminum.

## CONTENTS

### Product Overview

### Basic Information

- 04 Basic Structure
- 04 Axis System
- 05 Spindle
- 05 Table
- 06 Tool Change System
- 06 Magazine

### Detailed Information

- 07 Standard / Optional Specifications
- 08 Peripheral Equipment
- 09 DN SOLUTIONS FANUC i PLUS
- 10 EZ Work
- 11 Convenient Operation
- 12 Power | Torque
- 13 Table
- 14 Dimensions
- 16 Machine Specifications

### Customer Support Service

- 17 Why DN Solutions
- 18 Customer Support and Services
- 19 Global Network



**NON-CUTTING TIMES HAVE BEEN DRASTICALLY REDUCED TO REALIZE THE HIGHEST PRODUCTIVITY IN ITS CLASS.**



**OPTIMIZED MACHINE DESIGN FOR FAST MACHINING OF LIGHTWEIGHT MATERIALS.**



**SPINDLE RELIABILITY AND THERMAL DISPLACEMENT OPTIMIZATION**



- Acceleration/Deceleration rates for the spindle and axis drives have been optimized to ensure high productivity.
- Tool change times (T-T-T and C-T-C) have been improved to reduce the non-cutting time between machining operations.

- A range of features are available to meet the customers' machining requirements, such as the automatic ATC shutter and programmable coolant nozzles.

- The thermal displacement correction function is applied as standard to optimize machining accuracy and to compensate for temperature variations in the surrounding environment.
- DN Solutions's direct connection spindle motor technology is applied to minimize noise and vibration and ensure a high level of reliability over long periods of operation.
- Grease lubrication is used as standard to reduce running costs and provide an eco-friendly operation.



# BASIC STRUCTURE

The SVM machine incorporates DN Solutions's traditional C-frame design structure, but has been optimized for higher productivity when undertaking fast and light duty machining operations.

## Travel distance (X x Y x Z axis)

### SVM 4100

X-axis **770** mm (30.3 inch)

Y-axis **410** mm (16.1 inch)

Z-axis **510** mm (20.1 inch)

### SVM 5100L

X-axis **1270** mm (50.0 inch)

Y-axis **510** mm (20.1 inch)

Z-axis **510** mm (20.1 inch)



# AXIS SYSTEM

Non-cutting times have been drastically reduced by optimizing the acceleration/deceleration rates for the axis feed systems.

## Rapid traverse rate (X / Y / Z axis)

**36 / 36 / 36** m/min  
(1417.3 / 1417.3 / 1417.3 ipm)

## Acceleration/deceleration time (G)

### SVM 4100

**0.7 / 0.6 / 0.6**

### SVM 5100L

**0.6 / 0.5 / 0.6**

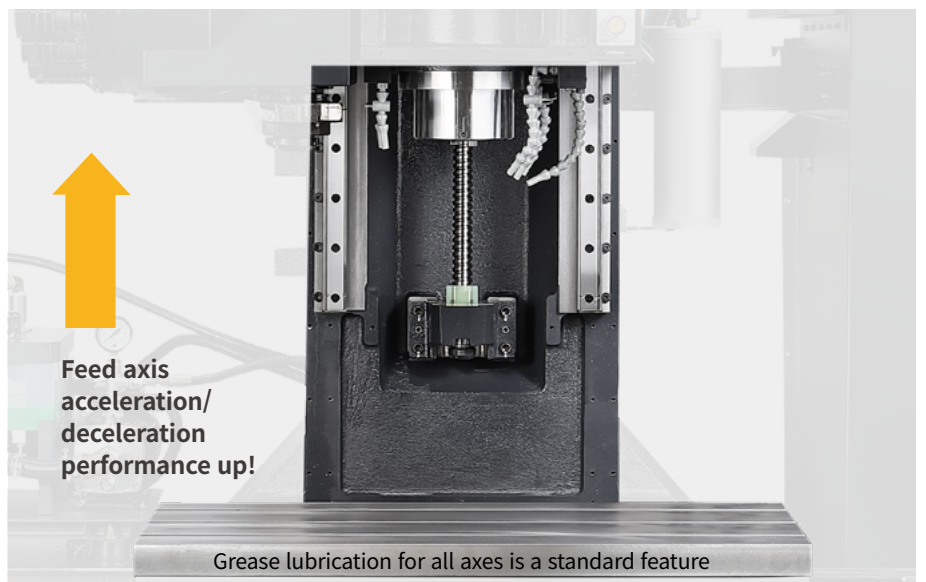

# SPINDLE

Optimized machine table size and maximum allowable load capacity provide the largest machining area in its class.

Max. spindle speed

**12000** r/min

Max. spindle motor power

**18.5** kW (24.8 Hp)

Max. spindle motor torque

**95.5** N·m (70.5 ft-lbs)



Spindle  
acceleration/  
deceleration  
performance up!

# TABLE

The direct connection type spindle is supplied as standard. The noise and vibration levels are reduced to improve operator comfort.

Table size (A x B)

SVM 4100

**920 x 410** mm (36.2 x 16.1 inch)

SVM 5100L

**1320 x 510** mm (52.0 x 20.1 inch)

Max weight on table (W)

SVM 4100

**600** kg (1322.8 lb)

SVM 5100L

**800** kg (1763.7 lb)

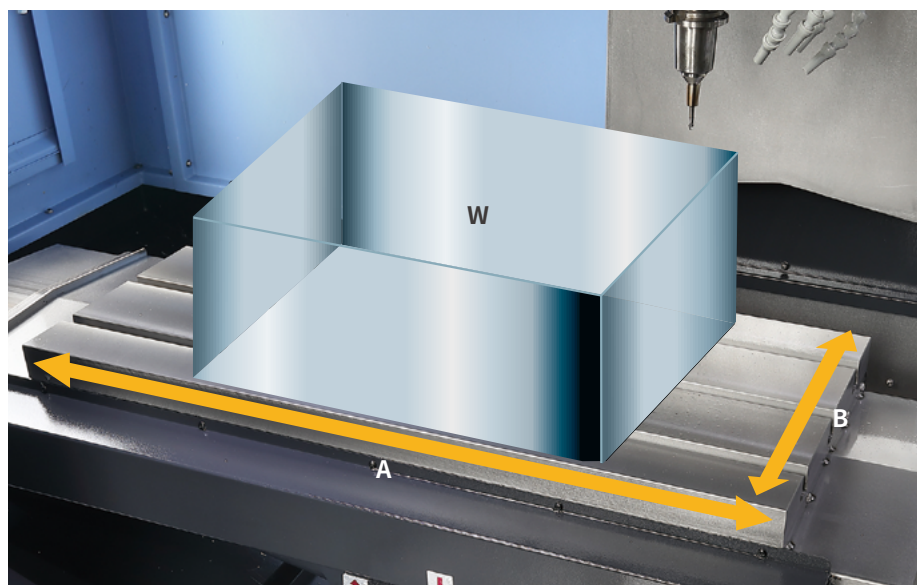

# TOOL CHANGE SYSTEM

In order to reduce the non-cutting time between machining operations, the tool change time has been optimized compared to similar models.

Tool to tool time

**1.3 S**

Chip to chip\* time

**3.3 S**

\* The Chip-to-Chip time has been tested in accordance with DN Solutions's strict testing procedures, but may vary depending on different operating conditions.



# MAGAZINE

Tool storage capacity

**30 ea**

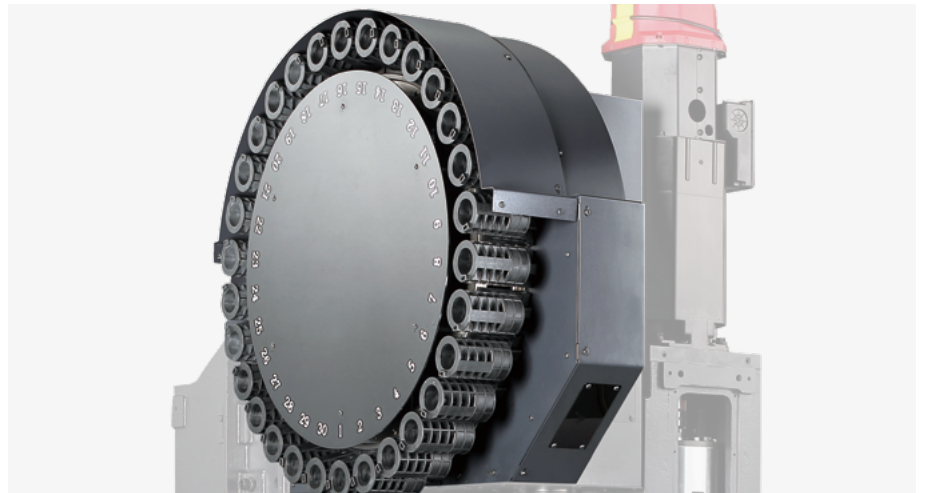

## Brush (std.)

A barrier brush is used to prevent chip ingress into ATC area during machining.

## ATC shutter OPTION

An ATC shutter door can be specified instead of the brush to provide a higher level of protection from chip ingress.

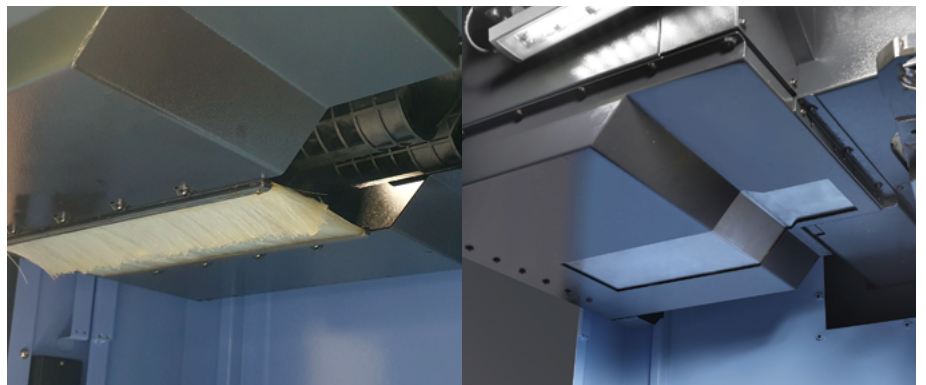

# STANDARD | OPTIONAL SPECIFICATIONS

Various optional features are available to satisfy customers' specific machining applications.

Description	Features		SVM 4100 / SVM 5100L	
<b>Spindle</b>	12000 r/min (Unit: kW(Hp), N·m(ft·lbs))	18.5/5.5 kW (24.8/7.4 Hp), 95.9 N·m (70.5 ft·lbs)	●	
<b>Magazine</b>	Tool storage capacity	30 ea	●	
<b>Tool shank type</b>	BIG PLUS BT40		●	
	BIG PLUS CAT40		○	
	BIG PLUS DIN40		○	
<b>Coolant system</b>	200L/min (1.1kW)	SVM 4100	●	
	0.19MPa, 0.4kW	SVM 5100L	●	
	0.69MPa, 1.1kW	SVM 5100L	○	
	SVM 4100	Flood + Base (Tank capacity/Pump motor power)	280 L/1.1 kW	●
		Flood + Base + PFC (Tank capacity/Pump motor power)	280 L/ 1.1 kW	○
		TSC Middle (Tank capacity/Pump motor power)	280 L/1.5 kW	○
		TSC Middle 2 (Tank capacity/Pump motor power)	140 L/2.9 kW	○
		TSC High (Tank capacity/Pump motor power)	140 L/7.5 kW	○
		Shower coolant (Tank capacity/Pump motor power)	280 L/1.1 kW	○
		Top flushing (Tank capacity/Pump motor power)	280 L/1.1 kW	○
	SVM 5100L	Coolant gun (Tank capacity/Pump motor power)	280 L/0.6 kW	○
		Flood coolant (Tank capacity/Pump motor power)	380 L/0.4 kW	●
		Flood coolant 2 (Tank capacity/Pump motor power)	380 L/1.1 kW	○
		TSC Middle (Tank capacity/Pump motor power)	380 L/1.5 kW	○
		TSG Middle 2 (Tank capacity/Pump motor power)	140 L/2.9 kW	○
		TSC High (Tank capacity/Pump motor power)	140 L/7.5 kW	○
		Shower coolant (Tank capacity/Pump motor power)	380 L/1.1 kW	○
		Top flushing (Tank capacity/Pump motor power)	380 L/1.8 kW	○
		Coolant gun (Tank capacity/Pump motor power)	380 L/0.6 kW	○
	<b>Chip disposal</b>	Chip conveyor	Chip pan	●
Hinged type (Left/Right)			○	
Magnetic scraper type (Left/Right)			○	
Chip bucket			○	
Air blower			○	
AIR GUN			○	
<b>Precision machining option</b>	Linear scale	X / Y / Z axis	○	
	HSCC (700 block)		●	
	Spindle thermal compensation function	SENSORLESS TYPE	●	
<b>Measurement &amp; Automation</b>	Automatic tool measurement	TS27R_Renishaw	○	
		ZX Speed_Blum	○	
		OTS_Renishaw	○	
		NC4_Renishaw	○	
	Automatic tool breakage detection		○	
	Automatic workpiece measurement	OMP60_Renishaw	○	
TC50_Blum		○		
Automatic front door with safety edge		○		
<b>4 axis Rotary table</b>	S-200	SVM 4100 / SVM 5100L	○	
	S-250	SVM 5100L	○	
	S-320	SVM 5100L	○	
	4 axis Ready	Cabling for Servo/1-Pneumatic piping	○	
<b>Accessories</b>	LED lamp		●	
	3-Color signal tower(LED)		●	
	Auto power off		○	
<b>Customized Special Option</b>	Anchoring	Slide clamp & Chemical anchor bolt	○	
	Water soluble Coolant Chiller**		○	
	Automatic tool measurement	LTS_Renishaw	○	
	Automatic tool breakage detection	MSC/BK9 (Needle type on magazine)	○	
	Raising Column		○	

\* Please contact DN Solutions to select detail specifications

● Standard ○ Optional X Not applicable

\*\* When using a semi-synthetic type or synthetic type, contact our sales representative or service center in advance.

\*\* Technical consultation is mandatory for the chilling of non-water soluble coolant

 Fire Safety | There is a high risk of fire when using non-water-soluble cutting fluids, processing flammable materials, neglecting the controlled and careful use of coolants and modifying the machine without the consent of the manufacturer. Always check the SAFETY GUIDELINES carefully before using the machine.

# PERIPHERAL EQUIPMENT

## Chip conveyor OPTION



Chip conveyor type	Material	Description
Hinged belt	Steel	Hinged belt chip conveyor, which is most commonly used for steel work [for cleaning chips longer than 30mm(1.2inch)], is available as an option.
Magnetic scraper	Cast Iron	Magnetic scraper type chip conveyor, which is ideal for die-casting work [for cleaning small chips], is available as an option.

## Hydraulic / Pneumatic fixture line OPTION

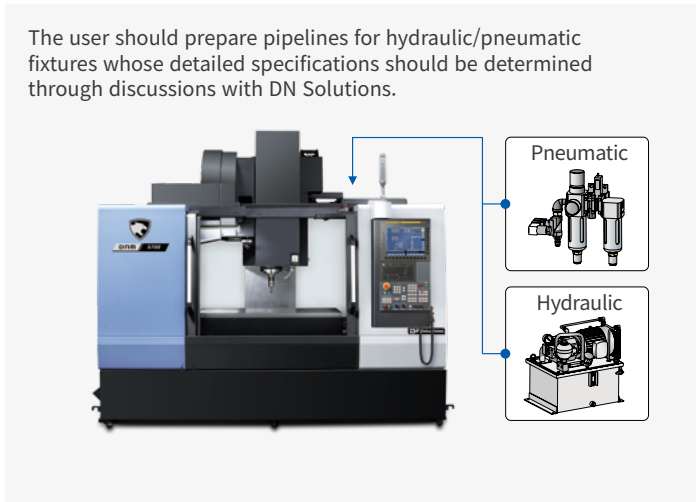

## 4 axis rotary table OPTION

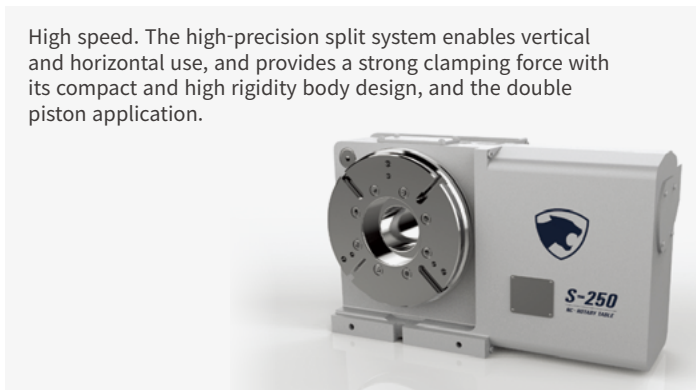

## PFC(Programmable flood coolant)

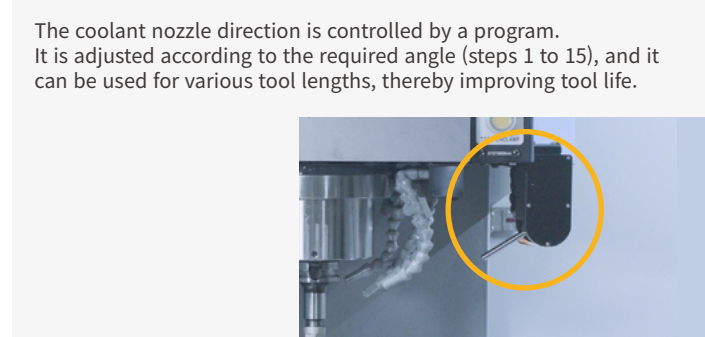

## Coolant chiller OPTION

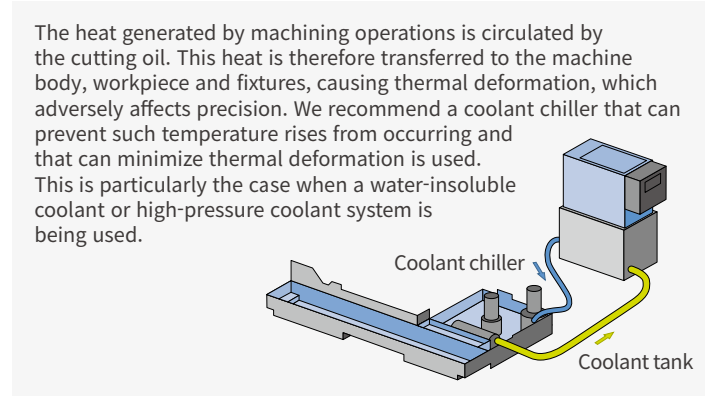

## Chip bucket OPTION

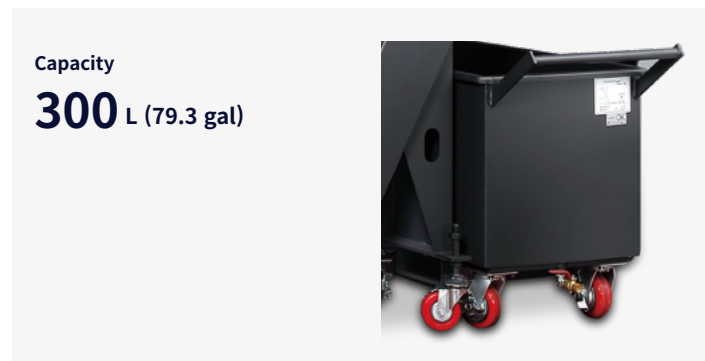

## Grease lubrication system

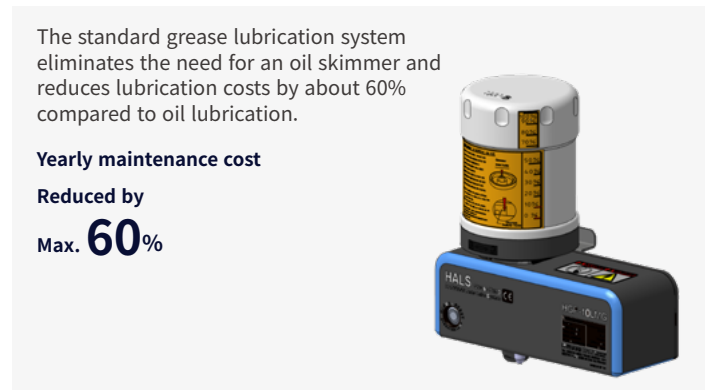

# DN SOLUTIONS FANUC i PLUS

DN Solutions Fanuc i Plus is optimized for maximizing customer productivity and convenience.

## 15 inch screen + new operation panel

DN Solutions Fanuc i Plus' operation panel enhances operating convenience by incorporating common-design buttons and layout, and features the Qwerty keyboard for fast and easy operation.

## DN Solutions Fanuc i Plus

- 15 inch color display
- Intuitive and user-friendly design

## USB & PCMCIA card QWERTY keyboard

- EZ-guide i standard
- Ergonomic operator panel
- 2MB Memory
- Hot key



## iHMI touchscreen OPTION

iHMI provides an intuitive interface that uses a touchscreen for quick and easy operation.

## Range of applications

Providing various applications related to planning, machining, improvement and utility, for customer convenience.



## NUMERIC CONTROL SPECIFICATIONS



Item	Specifications	DN Solutions Fanuc i (0i PLUS) SVM 4100 / SVM 5100L
Controlled axis	Controlled axes	3 (X,Y,Z)
	Simultaneously controlled axes	3 axis
Data input/output	Additional controlled Axis	●
	Fast data server	○
	Memory card input/output	●
	USB memory input/output	●
Interface function	Large capacity memory(2GB) <sup>*2)</sup>	○
	Available Option only with 15" Touch LCD (iHMI Only) <sup>*2)</sup>	○
	Embedded Ethernet	●
	Fast Ethernet	○
Operation	Enhanced Embedded Ethernet function	●
	DNC operation	Included in RS232C interface.
	DNC operation with memory card	●
Program input	Workpiece coordinate system	G52 - G59
	Addition of workpiece coordinate system	G54.1 P1 X 48 (48 pairs)
	Tool number command	T4 digits
Feed function	Tilted working plane indexing command	G68.2 TWP
	AI contour control I	G5.1 Q_, 40 Blocks
	AI contour control II	G5.1 Q_, 200 Blocks
	AI contour control II	G5.1 Q_, 600 Blocks
	AI contour control II	G5.1 Q_, 1000 Blocks <sup>*1)</sup>
Operation guidance function	High smooth TCP	X
	EZ Guidei (Conversational Programming Solution)	●
	iHMI with Machining Cycle	Only with 15" Touch LCD standard <sup>*2)</sup>
Setting and display	EZ Operation package	X
	CNC screen dual display function	●
Network	FANUC MTConnect	⊕
	FANUC OPC UA	⊕
Others	Display unit	10.4" color LCD
		15" color LCD
		15" color LCD with Touch Panel
		640M(256KB)_500 programs
		1280M(512KB)_1000 programs
		2560M(1MB)_1000 programs
		5120M(2MB)_1000 programs
		10240M(4MB)_1000 programs
		20480M(8MB)_1000 programs
		2560M(1MB)_2000 programs
		5120M(2MB)_4000 programs
		10240M(4MB)_4000 programs
		20480M(8MB)_4000 programs
		Part program storage size & Number of registerable programs

\*1) The number of look-ahead blocks may be changed or limited depending on the peripheral device or the configuration of the internal NC system.  
\*2) Available Option only with Fanuc i plus iHMI

● Standard ○ Optional X N/A ⊕ Available  
Network: FANUC MT Connect and FANUC OPC UA available.

# EZ WORK

## EZ work

The software developed by DN Solutions features numerous functions designed for convenience and ease of operation. The EZ work delivers speed and efficiency. This menu-driven innovation not only helps customers reduce setup times, but also simplifies common tasks and procedures, reducing the potential for errors. EZ work reduces operating time, protects machinery, enhances quality and speeds up maintenance interventions.

### Conversational convenient function



#### EZ work Main screen

On the operation panel, press the CUSTOM1 button to display the initial EZ work screen.

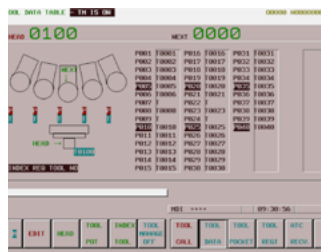

#### Tool management

This function controls information on the tools in the tool magazine pots.

### Pop-up function

Various EZ work functions can be monitored through the pop-up window on the NC main screen. (Press the CUSTOM2 button)

- ① Display machining program
- ② Tool Load Monitoring
- ③ Tool management data
- ④ M code list
- ⑤ G code list
- ⑥ Tool & Workpiece count



#### ATC recovery

In the event of an error during ATC (automatic tool changer) operations, follow the on-screen instructions for an easy and prompt solution.



#### Tool load monitoring

During cutting operations, abnormal loads caused by wear and tear of the tool are detected and an alarm is triggered to prevent further damage.

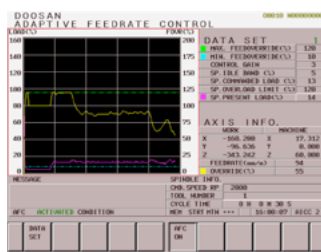
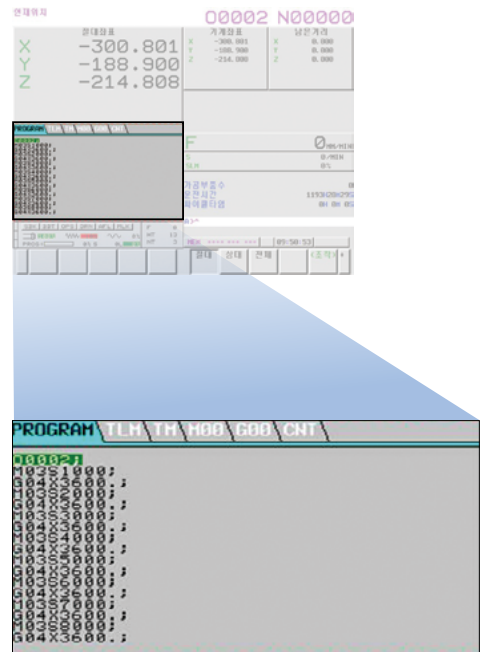

#### Adaptive Feed Control(AFC)

If tool overload is detected during operation, the feed rate is controlled to prevent the tool from being damaged.



#### Thermal compensation function

A thermal error compensation function is provided as a standard feature to ensure stable cutting operations safe from potentially harmful environmental factors.

# CONVENIENT OPERATION

## SIEMENS 828D

### 15.6" screen + new operation panel

The newly-designed operation panel improves the customer convenience by incorporating and using common-design buttons and layouts, and includes the familiar QWERTY keyboard for fast and easy operation.

- 15.6" display
- 10MB high capacity user memory
- USB & ethernet (standard)
- QWERTY keyboard (standard)
- High-speed calculation and simulation can be fulfilled by improved processor functionality



### Conversational convenient function

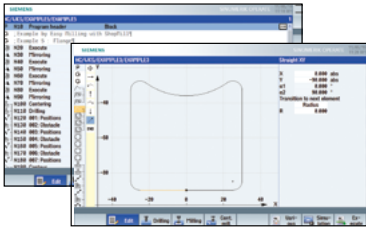

Shop Mill Part Programming

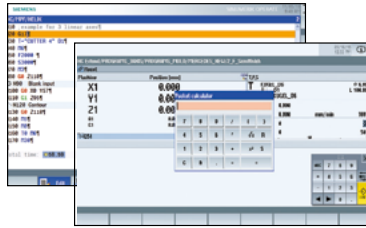

Smart function

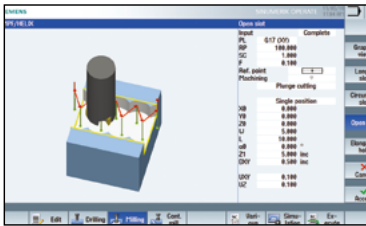

Advanced program language programGUIDE

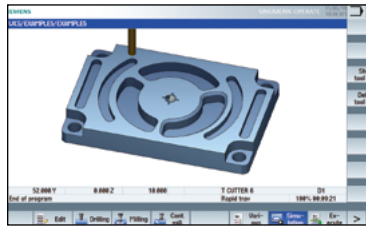

Simulation and machining contour monitoring

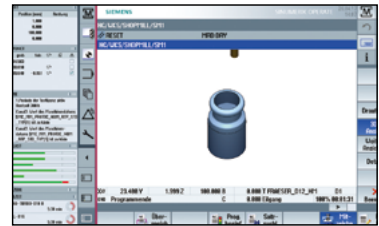

Side screen widget

## NUMERIC CONTROL SPECIFICATIONS

SIEMENS

Item	Specifications	S828D	
		SVM 4100 / SVM 5100L	
Controlled axis	Controlled axes	-	3 axis
	Simultaneously controlled axes	-	3 axis
Data input/output	Memory card input/output	(Local drive)	X
	USB memory input/output		●
Interface function	Ethernet	(X130)	●
Operation	On network drive	(without EES option, Extcall)	●
	On USB storage medium, e.g. memory stick	(without EES option, Extcall)	●
Program input	Workpiece coordinate system	G54 - G57	●
	Addition of workpiece coordinate system	G505 - G599	●
Interpolation & Feed function	Advanced surface		●
	Top surface		○
	Look ahead number of block	S/W version 4.95	450
Programming & Editing function	3D simulation, finished part		●
	Simultaneous recording		●
	Measure kinematics		X
Operation Guidance Function	DXF Reader for PC integrated in SINUMERIK Operate		○
	ShopMill		●
Setting and display	EZ Work		●
	Operation via a VNC viewer		●
Network	MTConnect		⊕
	OPCUA		○
Etc. function	15.6" color display with touch screen		●
	19" color display without touch screen		X
	21.5" color display with touch screen		X
	CNC user memory	10 MB	●
	Expansion by increments	2 ~ 12 MB	○
	Collision avoidance		X
Collision avoidance ECO (machine, working area)		X	

# POWER | TORQUE

## FANUC

**SPEED**

**12000** r/min

**POWER**

**18.5** kW (24.8 hp)

**TORQUE**

**95.5** N·m (70.5 ft-lbs)

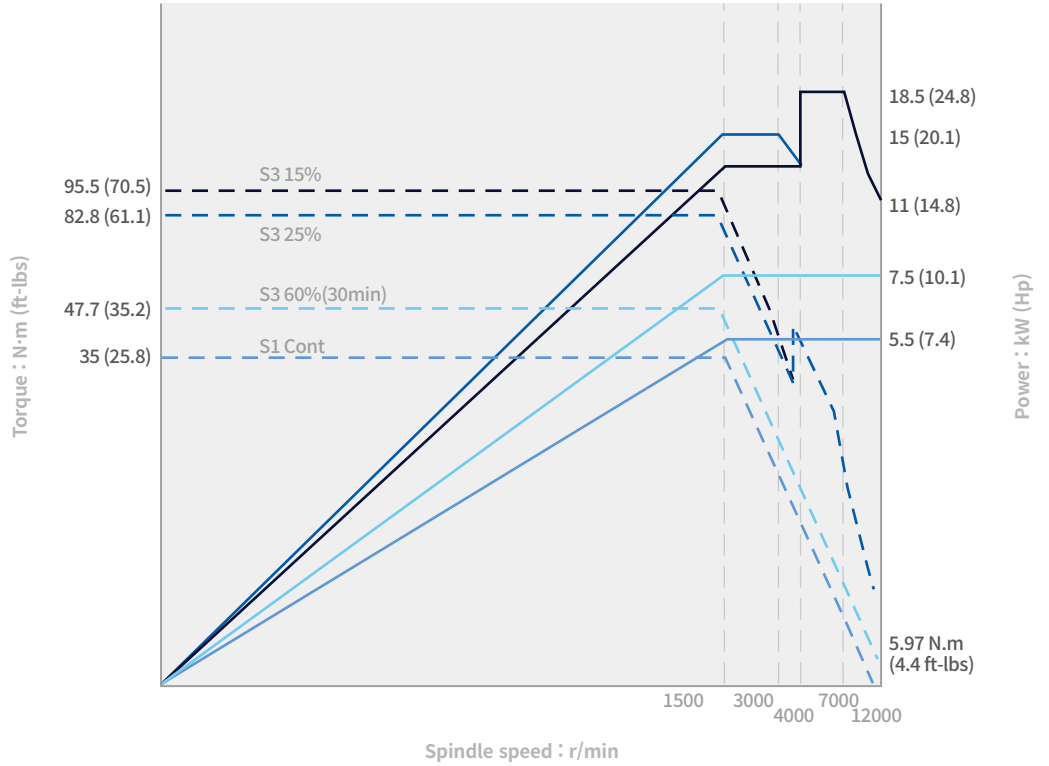

## SIEMENS\*

**SPEED**

**12000** r/min

**POWER**

**11.3** kW (15.2 hp)

**TORQUE**

**72** N·m (53.1 ft-lbs)

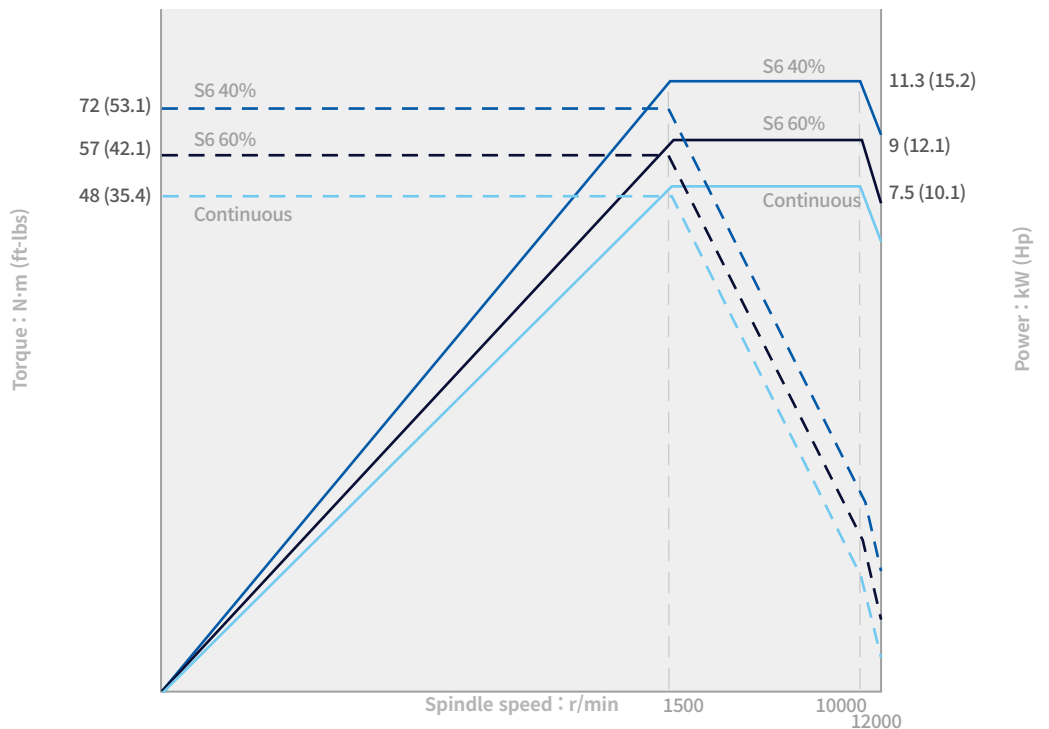

\*available only for SVM 4100

# TABLE

## SVM 4100

Unit : mm (inch)

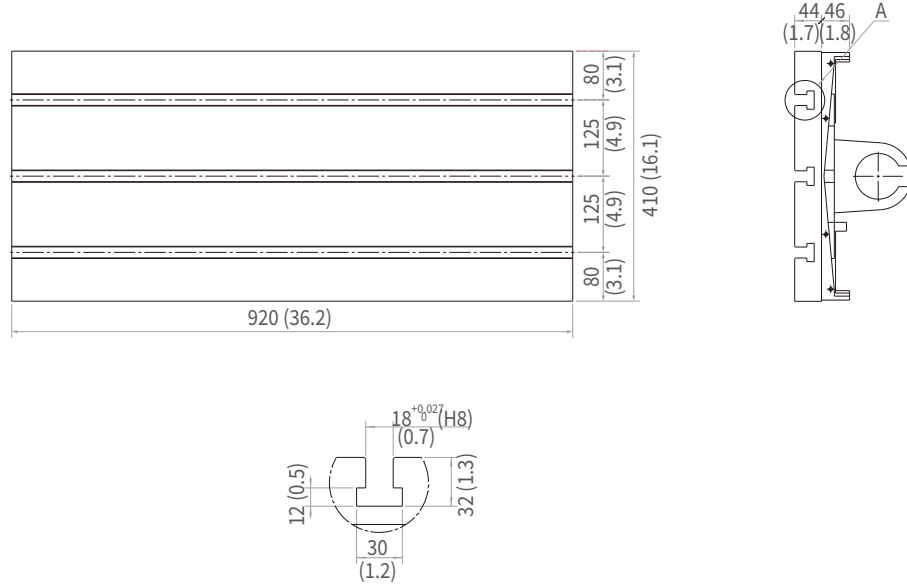

## SVM 5100L

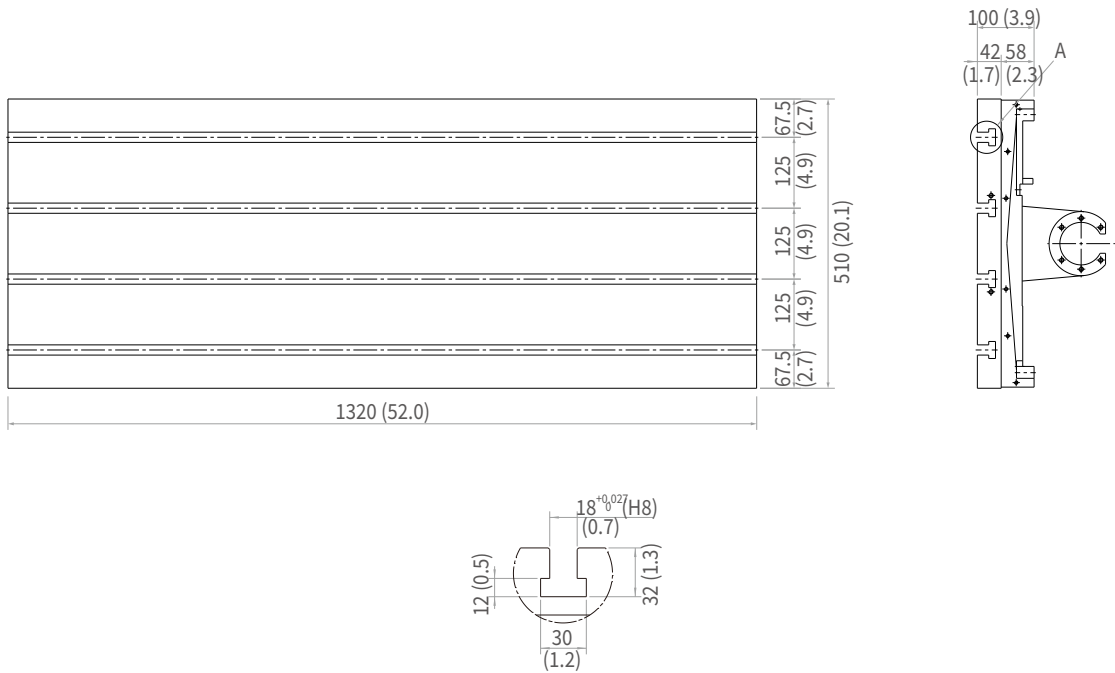

# DIMENSIONS

## SVM 4100

Unit : mm (inch)

TOP

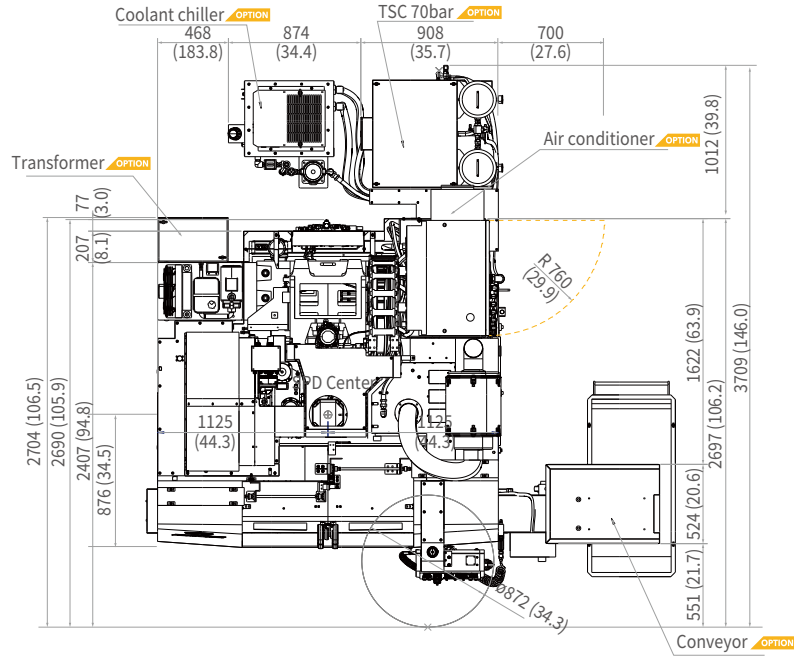

FRONT

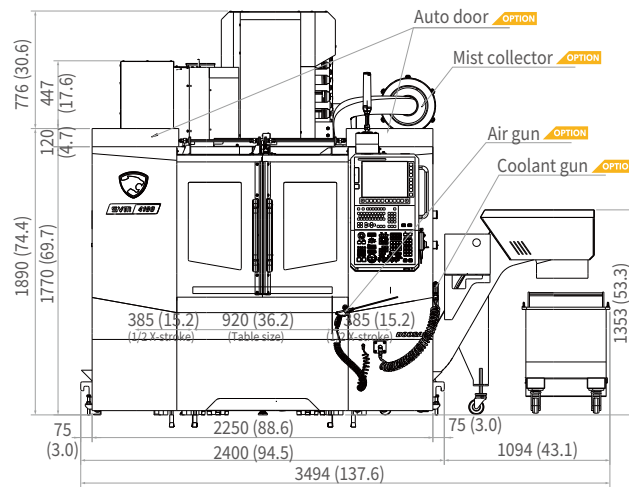

SIDE

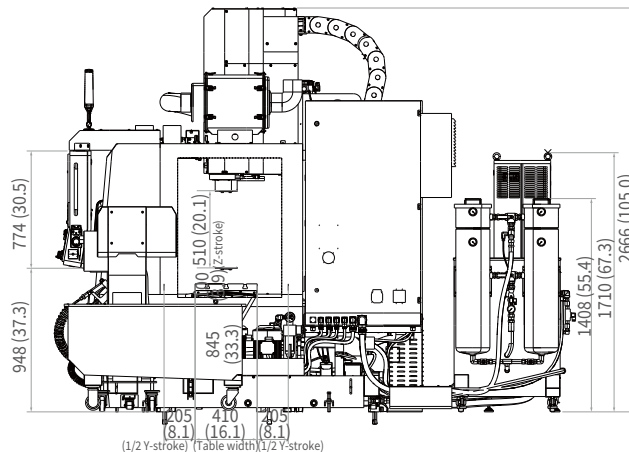

# DIMENSIONS

## SVM 5100L

TOP

Unit : mm (inch)

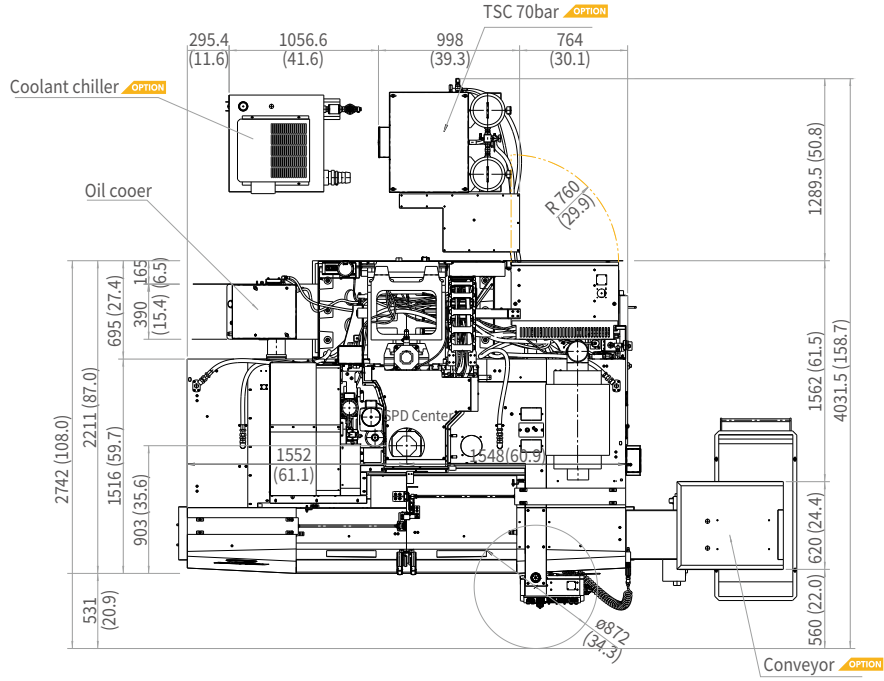

FRONT

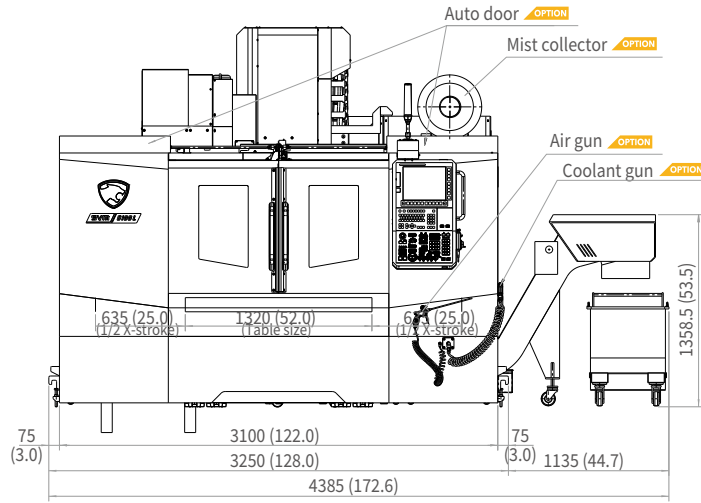

SIDE

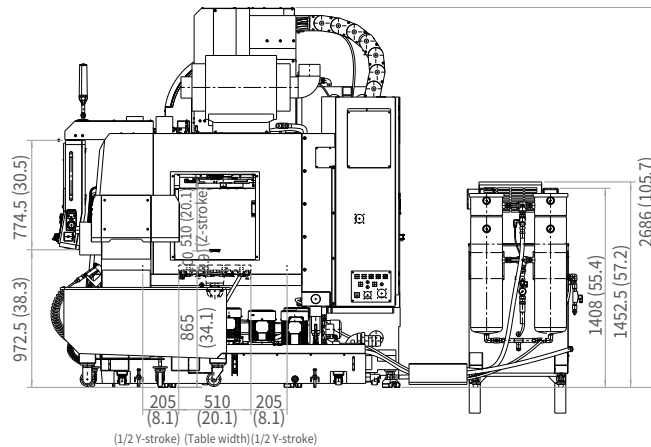

\* Some peripheral equipment can be placed in other areas.

# MACHINE SPECIFICATIONS

Description		Unit	SVM 4100	SVM 5100L	
Travels	Travel distance	X axis	770 (30.3)	1270 (50.0)	
		Y axis	410 (16.1)	510 (20.1)	
		Z axis	510 (20.1)		
	Distance from spindle nose to table top	mm (inch)	100~610 (3.9~24.0)		
Table	Table size	mm (inch)	920 x 410 (36.2 x 16.1)	1320 X 510 (52.0x 20.1)	
	Table loading capacity	kg (lb)	600 (1322.8)	800 (1763.7)	
	Table surface type	mm	T-SLOT (3-125 x 18H8)	T-SLOT (4-125 x 18H8)	
Spindle	Max. spindle speed	r/min	12000		
	Taper	-	ISO #40		
	Max. spindle torque	N·m (ft-lbs)	95.5 (70.5)		
	Max. spindle power (S3/continuous)	kW (Hp)	18.5/5.5 (24.8/7.4)		
Feedrates	Rapid traverse rate	X axis	36 (1417.3)		
		Y axis	36 (1417.3)		
		Z axis	36 (1417.3)		
Automatic tool changer	Type of tool shank	-	BT 40 {CAT/ DIN}		
	Tool storage capa.	m/min (ipm)	30		
	Max. tool diameter	Continuous	mm (inch)	80 (3.1)	
		Without adjacent tools	mm (inch)	125 (4.9)	
	Max. tool length	mm (inch)	300 (11.8)		
	Max. tool weight	kg (lb)	6 (13.2)		
	Tool selection		MEMORY RANDOM		
	Tool change time (Tool-to-tool)	sec	1.3		
Tool change time (Chip-to-chip)	sec	3.3			
Motor	Coolant pump motor power	kW (Hp)	1.1 (1.5)	0.4 (0.54)	
Power source	Electric power supply (rated capacity)	kVA	24.8	28.5	
	Compressed air supply	MPa (psi)	0.54		
Tank capacity	Coolant tank capacity	L (gal)	240 (63.4)	380 (100.4)	
Machine dimensions	Height	mm (inch)	2661 (104.8)	2681 (105.6)	
	Length	mm (inch)	2300 (90.6)	2410 (95)	
	Width	mm (inch)	2250 (88.6)	3100 (122.0)	
	Weight	kg (lb)	4100 (9038.8)	5820 (12831)	
Control	NC system	-	FANUCi-SERIES SIEMENS S828D	FANUC i-SERIES	

# WHY DN SOLUTIONS

The DN Solutions promise, MACHINE GREATNESS, has two important meanings. The first is simple: DN Solutions makes great machines. The second is a challenge to our end-users. With a product line that is this comprehensive, accurate and reliable, we equip our customers to machine greatness. The big question: *Why should you choose DN Solutions over other options?* Here's why...

## UNBEATABLE MACHINES

You won't find a more comprehensive range or a better combination of value, performance and reliability anywhere else.

## ROBUST PRODUCT LINE

We offer an impressive range of machine models and hundreds of configurations. Whatever your machining needs and requirements, there's a DN Solutions for you.

## READILY AVAILABLE - ANYWHERE IN THE WORLD

Machining centres (including 5-axis machines), lathes, multi-tasking turning centres and mill-turn machines, and horizontal borers with best-in-class specifications are all available...ready to install.

## EXPERT SERVICE

Our dedicated, experienced and knowledgeable team is totally committed to improving your productivity, growth and success.

# CUSTOMER SUPPORT AND SERVICES

## WE'RE THERE FOR YOU WHENEVER YOU NEED US.

We help our customers operate at maximum efficiency by providing them with a range of tried, tested and trusted services - from pre-sales consultancy to post-sales support.



### FIELD SERVICES

- On-site service
- Machine installation and testing
- Scheduled preventive maintenance
- Machine repair service



### PARTS SUPPLY

- Supplying a wide range of original DN Solutions spare parts
- Parts repair service



### TRAINING

- Programming, machine setup and operation
- Electrical and mechanical maintenance
- Applications engineering



### TECHNICAL SUPPORT

- Supports machining methods and technology
- Responds to technical queries
- Provides technical consultancy

# RESPONDING TO CUSTOMERS **ANYTIME, ANYWHERE**

## DN SOLUTIONS GLOBAL NETWORK

DN Solutions provides systems-based professional support services, before and after the machine tool sale, by responding quickly and efficiently to customers. By supplying spare parts, product training, field service and technical support, we provide the expert care, attention and assistance our customers expect from a market leader.



<b>66</b>	COUNTRIES
<b>140+</b>	SALES NETWORKS
<b>3</b>	FACTORIES
<b>6</b>	REGIONAL HQS





**Head Office**

19F, 10, Tongil-ro, Jung-gu, Seoul,  
Republic of Korea, 04527

Tel: +82-2-6972-0370  
Fax: +82-2-6972-0400

**DN Solutions America**

360 E State PKWY,  
Schaumburg, IL. 60173,  
United states

Tel: +1-315-265-7500

**DN Solutions Europe**

Emdener Strasse 24, D-41540  
Dormagen, Germany

Tel: +49-2133-5067-100  
Fax: +49-2133-5067-111

**DN Solutions India**

No.82, Jakkuar Village  
Yelahanka Hobil,  
Bangalore-560064

Tel: +91-80-2205-6900  
E-mail: [india@dncompany.com](mailto:india@dncompany.com)

**DN Solutions China**

Room 101,201,301,  
Building 39 Xinzhuan Highway  
No.258 Songjiang District  
China Shanghai (201612)

Tel: +86 21-5445-1155  
Fax: +86 21-6405-1472

**DN Solutions Vietnam**

M.O.R.E building 2F, 40A-40B Ut  
Tich Street, 04 Ward 04,  
District Tan Binh District,  
Ho Chi Minh City, Vietnam  
Tel: +84 28-7304-0163

**DN Solutions Mexico**

Avenida Parque Bicentenario  
#100 Nave M65L3-6,  
Fraccionamiento San Isidro  
Business Park,  
Santa Rosa Jauregui,  
Querétaro, México

E-mail: [efrain.figueroa@dncompany.com](mailto:efrain.figueroa@dncompany.com)

**Sales inquiry**

[sales@dncompany.com](mailto:sales@dncompany.com)